

Incremental encoders

EX approval ATEX II 2 G Ex db e IIC T5/T6 Gb and IECEx Ex db e IIC T5/T6 Gb

25...5000 pulses per revolution

EEx OG 9 - incremental



EEx OG 9

Technical data - electrical ratings

Voltage supply	9...30 VDC 5 VDC $\pm 5\%$ 9...26 VDC
Consumption w/o load	≤ 100 mA
Pulses per revolution	25...5000
Phase shift	$90^\circ \pm 20^\circ$
Scan ratio	40...60 %
Reference signal	Zero pulse, width 90°
Sensing method	Optical
Output frequency	≤ 120 kHz (pulses ≤ 1250) ≤ 250 kHz (pulses > 1250)
Output signals	K1, K2, K0 + inverted
Output stages	HTL TTL/RS422
Interference immunity	EN 61000-6-2
Emitted interference	EN 61000-6-3
Approval	CE

Features

- Encoder incremental / ATEX / IECEx
- Optical sensing method
- ATEX II 2 G Ex db e IIC T5/T6 Gb
- IECEx Ex db e IIC T5/T6 Gb
- Solid shaft $\varnothing 11$ mm
- Robust light-metal housing
- Output stage HTL or TTL
- Output stage TTL with regulator UB 9...26 VDC
- Big terminal box, turn by 90°

Optional

- Cable gland M20x1.5 or M25x1.5

Technical data - mechanical design

Size (flange)	$\varnothing 115$ mm
Shaft type	$\varnothing 11$ mm solid shaft
Admitted shaft load	≤ 200 N axial ≤ 350 N radial
Flange	EURO flange B10
Protection DIN EN 60529	IP 56
Operating speed	≤ 6000 rpm (T5, mechanical) ≤ 4500 rpm (T6, mechanical)
Operating torque typ.	4 Ncm
Rotor moment of inertia	290 gcm ²
Materials	Housing: aluminium die-cast Shaft: stainless steel
Ambient temperature	-40...+55 °C (25...360 pulses per revolution) -50...+55 °C (500...2500 pulses per revolution) -25...+55 °C (3072...5000 pulses per revolution)
Resistance	IEC 60068-2-6 Vibration 10 g, 50-2000 Hz IEC 60068-2-27 Shock 100 g, 6 ms
Explosion protection	II 2 G Ex db e IIC T5/T6 Gb Ex db e IIC T5/T6 Gb
Connection	Terminal box
Weight approx.	3.5 kg

Incremental encoders

EX approval ATEX II 2 G Ex db e IIC T5/T6 Gb and IECEx Ex db e IIC T5/T6 Gb
25...5000 pulses per revolution

EEx OG 9 - incremental

Part number

Incremental encoder

EEx OG 9 **DN**

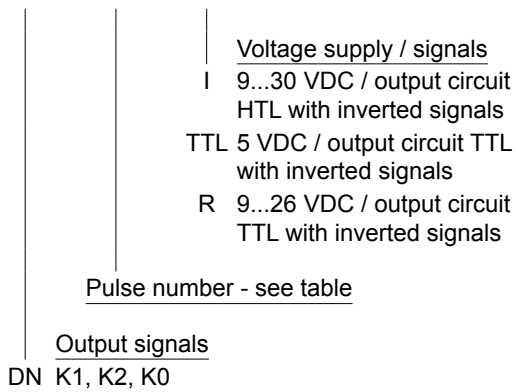

Accessories

Connectors and cables

HEK 8	Sensor cable for encoders
11106863	Extension cable gland M16 to M20

Mounting accessories

K 35	Spring washer coupling for solid shaft $\varnothing 6...12$ mm
K 50	Spring washer coupling for solid shaft $\varnothing 11...16$ mm
K 60	Spring washer coupling for solid shaft $\varnothing 11...22$ mm

Diagnostic accessories

HENQ 1100	Analyzer for encoders
-----------	-----------------------

Pulse number

25	256	1000	2500	5000
120	360	1024	3072	
128	500	1250	3600	
180	512	2048	4096	

Incremental encoders

EX approval ATEX II 2 G Ex db e IIC T5/T6 Gb and IECEx Ex db e IIC T5/T6 Gb

25...5000 pulses per revolution

EEx OG 9 - incremental

Output signals

At positive rotating direction

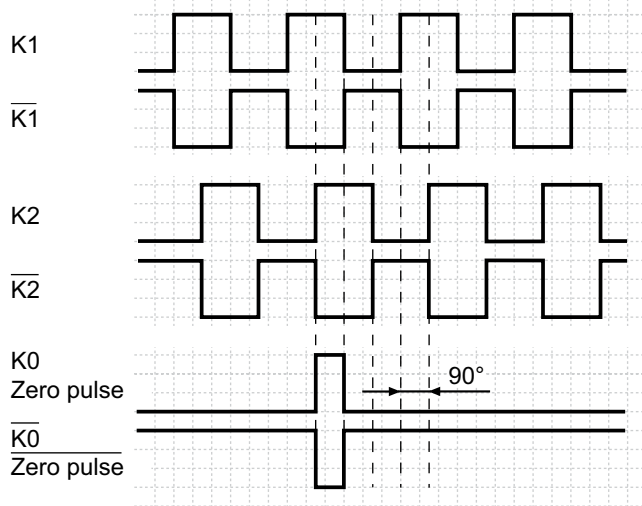

Terminal assignment

View A - Connecting terminal

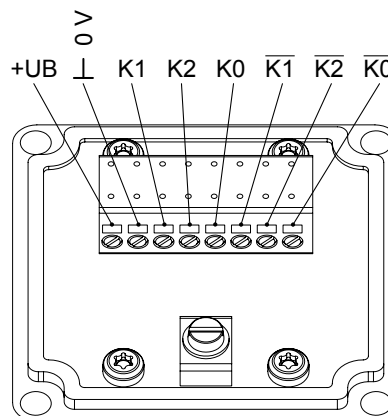

Incremental encoders

EX approval ATEX II 2 G Ex db e IIC T5/T6 Gb and IECEx Ex db e IIC T5/T6 Gb
25...5000 pulses per revolution

EEx OG 9 - incremental

Dimensions

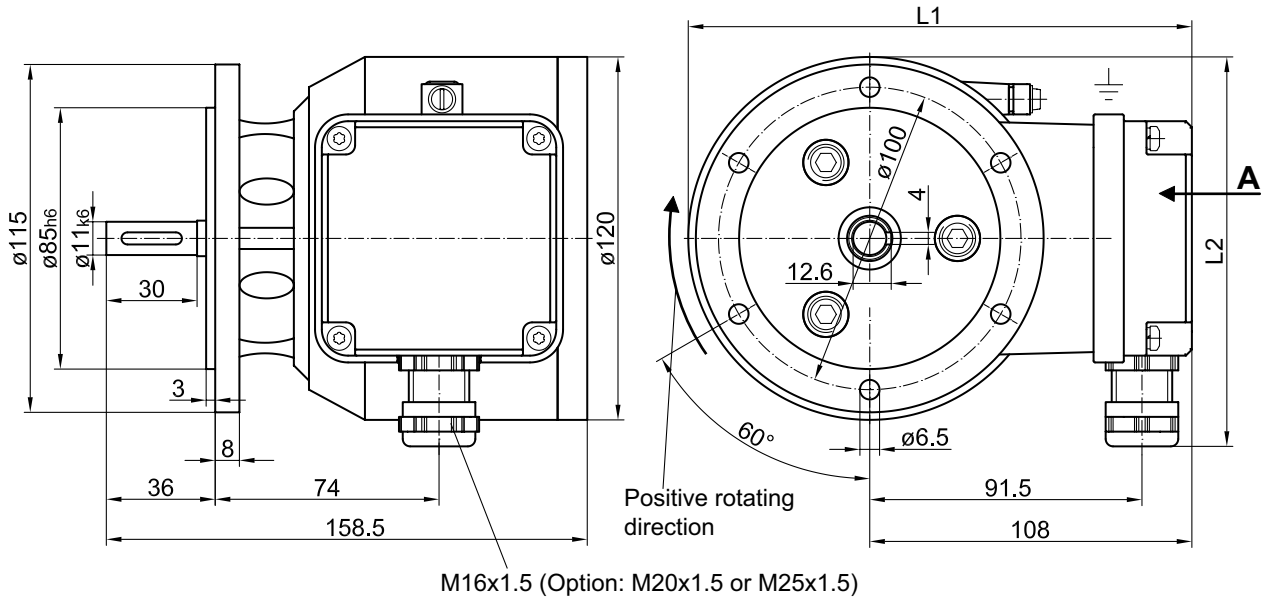

L1	L2	Cable gland
168	~125	M16x1.5
168	~145	M16x1.5 with extension to M20x1.5
168	~129	M20x1.5
177	~129	M25x1.5