

TC3YT

Connections

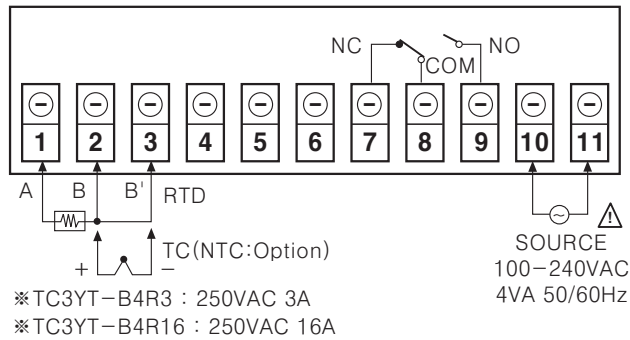

Dimensions

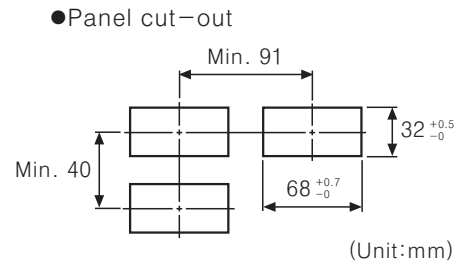
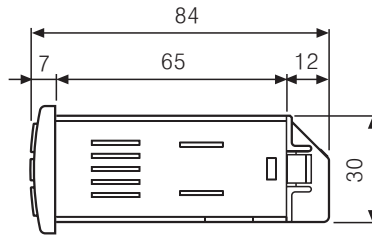
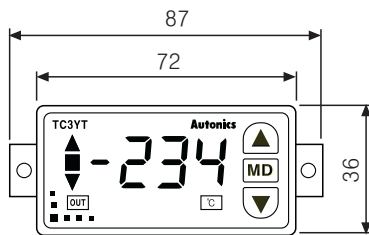

Front panel identification

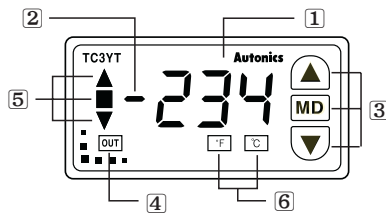

- ① PV(Process value) display(Red)
- ② Minus display(Red)
- ③ Controlling a set value(MD, UP, DOWN)
- ④ Display an operation of control output(Red)
- ⑤ Display a deviation between PV(Process value) and SV(Setting value) : ▲, ▼(Red) / ■(Green)
- ⑥ PV(Process value) °C/°F unit display(Yellow)

How to set and change setting value

Display for power ON

When power ON, it displays current temperature after temperature sensor and the type of control output flash twice(every 1 sec). In case of error, Error signal flashes instead of current temperature.

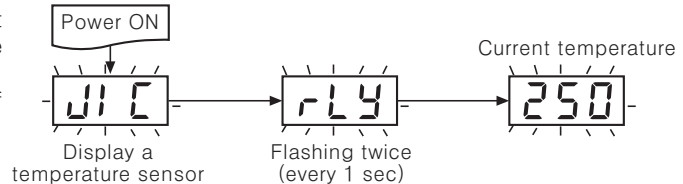

Check and set a Setting Value

- Setting value can be checked and set on operation mode.
- Press **[MD]** key on operation mode.

①Operation mode(display a current temperature)

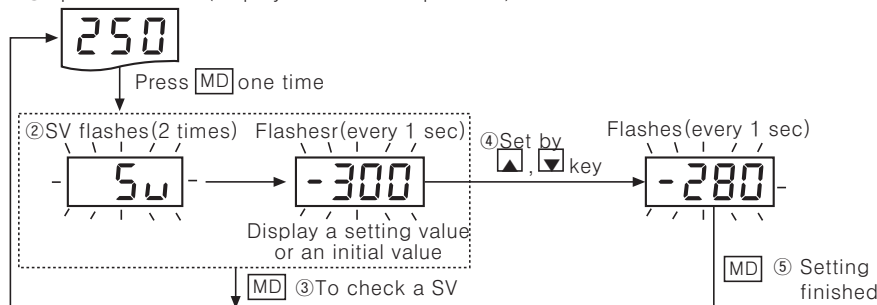

- ① Process value is displayed on operation mode,
- ② Press **[MD]** key, the setting value is indicated after "5.0" is flashing 2 times.
- ③ After check current value if press **[MD]** key, then it returned to the drive mode.
- ④ To change setting value, use **▲**, **▼** keys. If you press **▲**, **▼** keys continuously, the setting value is increases/decreases fast.
- ⑤ If press **[MD]** key after setting, the setting value is saved and the mode returns to operation.

※When there is no input for 1 min. for setting operation, it returns to operation mode and the setting value of parameter is not changed the prior value is saved.

Simple operation type of Temperature Controller

Input specification and range

Input		Input temperature range	
Sensor	Parameter	°C	°F
K	KCA	0 ~ 999	32 ~ 999
J	JIC	0 ~ 400	32 ~ 752
Pt H	PEH	0 ~ 400	32 ~ 752
Pt L	PEL	-99 ~ 199	-146 ~ 390

- *A temperature sensor converts temperature into electrical signal so that a controller can do ON/OFF the control output.
- *The setting is available~range : It is able to set in the temp. range shown above.
- *The setting range~temperature range : If it exceeds the range, it does not count.
- *Unit : It can be set as °C or °F and the unit is displayed.

Factory default

Setting group 1

Parameter	Description	Setting range	Unit	Factory default
P	Proportional band	0 ~ 100	%	0
t	The period of proportional control	1 ~ 120	sec	10
$r5t$	The correction value of offset for proportional control	0 ~ 100	%	50
HYS	Hysteresis for ON/OFF control	2 ~ 100	°C	2
$in.b$	Input correction value	-30 ~ 30	°C	0

Setting group 2

Parameter	Description	Setting range	Unit	Factory default
$in.t$	Temperature sensor	$\text{KCA}, \text{JIC}, \text{PEH}, \text{PEL}$	-	JIC
HSL	High-limit value of using temperature	See "Input specifications and range"	°C	400
LSL	Low-limit value of using temperature	See "Input specifications and range"	°C	0
oFt	Cooling/Heating operation	$\text{HEt} \leftrightarrow \text{CoL}$	-	HEt
oEr	Output for error	$\text{on} \leftrightarrow \text{oFF}$	-	oFF
$Un.t$	Temperature unit	$^{\circ}\text{C} \leftrightarrow ^{\circ}\text{F}$	-	$^{\circ}\text{C}$
LoC	Lock	$\text{oFF}, \text{LC1}, \text{LC2}, \text{LC3}$	-	oFF

Flow chart for setting group 1

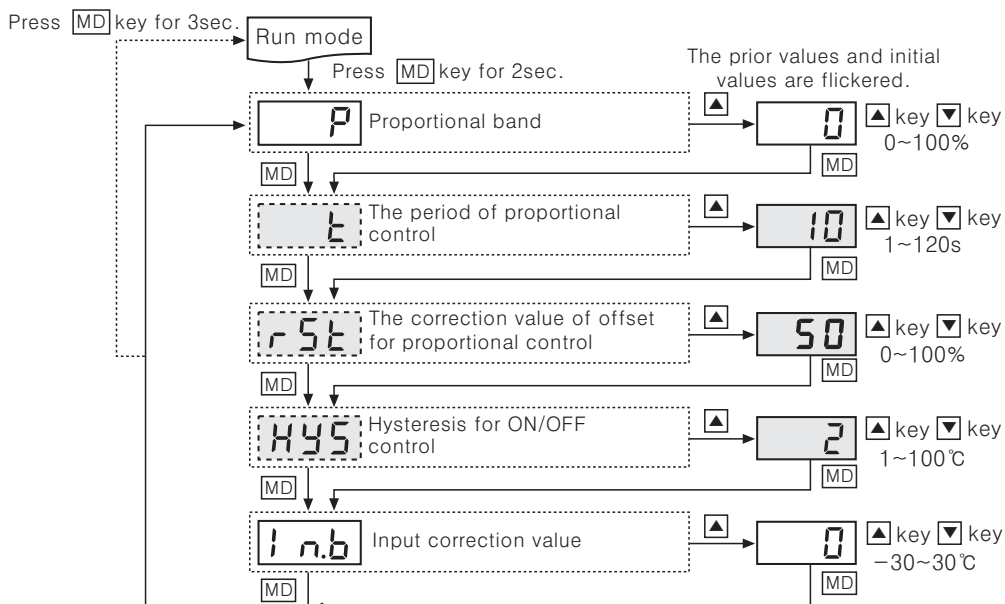

- In operation mode, if MD key is pressed for 2 sec., it enters into setting group 1.
- Pressing MD key, the initial mode of setting group 1, P is displayed for 2~3sec after displaying 5u and it enters into the initial mode of setting group 1 when releasing the MD key.
- Parameter of setting group 1 will be displayed.
- Pressing MD key, it moves to the next parameter and press ▲, ▼ key to change setting value.
- Press MD key in a changeable status or after changing the setting value, the changed value is saved and it moves to the next parameter.
- MD key is pressed for 3sec during the setting, the prior value is saved and it returns to the RUN mode.
- If there is no input for 1sec, it returns to RUN mode automatically and it holds the prior value.
- When P is not "0", [HYS] is not displayed.
- When P is "0", ON/OFF control, [t] and [r5t] are not displayed.
- *When it is entered to the setting mode, applicable parameters will be displayed.

(A)
Counter

(B)
Timer

(C)
Temp.
controller

(D)
Power
controller

(E)
Panel
meter

(F)
Tacho/
Speed/
Pulse
meter

(G)
Display
unit

(H)
Sensor
controller

(I)
Switching
power
supply

(J)
Proximity
sensor

(K)
Photo
electric
sensor

(L)
Pressure
sensor

(M)
Rotary
encoder

(N)
Stepping
motor &
Driver &
Controller

(O)
Graphic
panel

(P)
Production
stoppage
models &
replacement

Flow chart for setting group 2

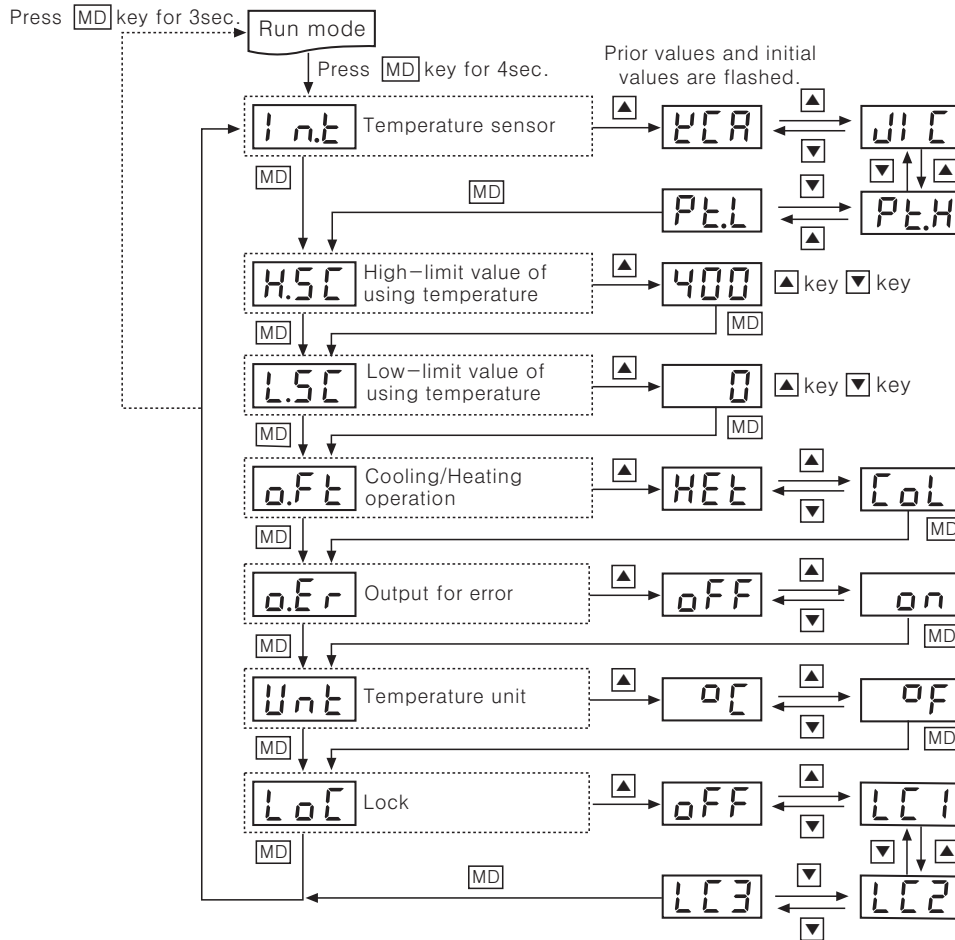

- In operation mode, if **[MD]** key is pressed for 4 sec., it enters setting group 2.
Pressing **[MD]** key, the initial mode of setting group 1, **P** is displayed for 2~3sec after displaying **Su** and **In.t**, the initial mode of setting group 2 is displayed at 4sec and it enters into the initial mode of setting group 2 when releasing the **[MD]** key. (Set value is flickering every one sec.)
- Parameter of setting group 2 will be displayed.
- Pressing **[MD]** key, it moves to the next parameter and press **[▲]**, **[▼]** key to change setting value.
- Press **[MD]** key in a changeable status or after changing the setting value, the changed value is saved and it moves to the next parameter.
- **[MD]** key is pressed for 3 sec during the setting, the prior value is saved and it returns to the RUN mode.
- If there is no input for 1 min, it returns to RUN mode automatically and it holds the prior value.
- ※ When it is entered to the setting mode, applicable parameters are displayed.
- ※ The unit LED is on after setting with **[MD]** key.

Function and operation

Input correction [**In.b**]

- It corrects deviation occurred from temperature sensor such as thermocouple, RTD etc.
- It is able to measure temperature precisely measuring and correcting the deviation.
- To use this function efficiently, the deviation occurring at the input sensor should be accurate to avoid additional variation.

Hysteresis [**HYS**]

- In ON/OFF control, hysteresis is required to avoid hunting such as chattering by external noise.
- In order to minimize regular hunting occurred by setting value of **HYS**, response of control object and sensor position, set it with proper **HYS** value, capacity of heater, sensor response and position etc.
- Setting range : 1 ~ 100°C (Factory default : 2°C)

Simple operation type of Temperature Controller

◎Proportional band[P]

- It is the proportional control interval for setting value when controlling during proportional interval.
- Setting range : 0 ~ 100%(Factory default : 0%)

◎Control interval (Proportional control)[t]

- When output the control value by using relay and SSR on the proportional control, it repeats ON/OFF for set time.
- The time interval set previously is proportional control interval.
- Setting range : 1 ~ 120s(Factory default: 10s)

◎Setting range

- Hysteresis / proportional band / proportional interval is set on parameter
- Setting range of hysteresis [HYS] : 1 ~ 100°C
- Setting range of proportional band [P] : 0 ~ 100%
- Setting range of control interval [t] : 1 ~ 120sec
- ON/OFF control↔Proportional control conversion : When P is 0%, it is ON/OFF control and if any value is set, it is proportional control. The parameter of hysteresis [HYS] appears when [P], proportional band, is 0%.

◎Offset correction / Manual reset [rSt]

- When use the proportional control, even it is in a stable statue, deviation can occur because of heat and heater capacity, it is offset.
- Offset is set on the parameter of inner manual reset [rSt].
- Offset correction is used only for proportional control. (Not for [P]=0%). Therefore if proportional band [P] is set as 0%, manual reset parameter [rSt] is not displayed.
- Setting range : 0~100% (Factory default : 50%)
- Set a value as 50% when process value is equal to setting value. After control is stable, if measured temperature is lower than setting value, set value is over than 50%, otherwise lower than 50%.
- Controlling a manual reset[rSt] by control result

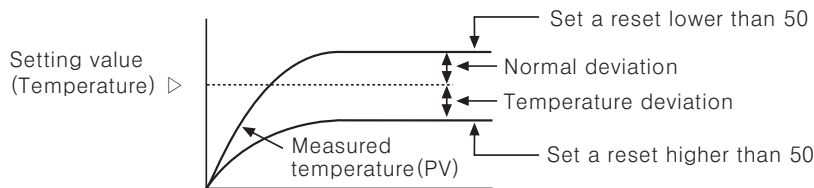

◎Control mode switch

- User can choose ON/OFF and proportional control.
- ON/OFF control – Proportional control conversion:
When P is 0%, it is ON/OFF control and if there is a value for P, is proportional control.
- Factory default : ON/OFF control(P : 0%)

◎The conversion of temperature unit(°C / °F)[UnE]

- By choosing °C or °F on temperature unit in setting parameter, [UnE] conversion is available.
- After choosing a temperature unit, LED is ON.
- Factory default : °C

◎Cooling / Heating operation

- Generally there are two ways to control temperature, one(heat-function) is to heat when process value is getting down(heater). The other(cool-function) is to cool when process is getting high refrigerator).
- Setting range: HEt(Heat) / Col(Cool) (factory default : HEt)

◎Display a process value deviation

- It displays the deviation between the process value and the setting value.
- When the process value is higher than the setting value(Process value > Setting value+2°C), △ is lighted.
- When the process value is lower than the setting value(Process value < Setting value-2°C), ▽ is lighted.
- When the deviation of the process value is within ±2°C, □ is lighted.

◎High/low limit setting for using temperature

- Set a high/low limit of temperature and the set range is within using range.
- If setting a high-limit of temperature on [H.SC], it is a high-limit setting value.
- If setting a low-limit of temperature on [L.SC], it is a low-limit setting value.
- L.SC ≤ Setting value ≤ H.SC. In case of L.SC= Setting value = H.SC, the output is OFF.
- If change L.SC and H.SC, the using range and proportional band also are changed.

(A)
Counter

(B)
Timer

(C)
Temp.
controller

(D)
Power
controller

(E)
Panel
meter

(F)
Tacho/
Speed/
Pulse
meter

(G)
Display
unit

(H)
Sensor
controller

(I)
Switching
power
supply

(J)
Proximity
sensor

(K)
Photo
electric
sensor

(L)
Pressure
sensor

(M)
Rotary
encoder

(N)
Stepping
motor &
Driver &
Controller

(O)
Graphic
panel

(P)
Production
stoppage
models &
replacement

◎ Error display

- If Error occurs during the operation, error signal flickers every one sec.

Display	Description
oPn	When the input sensor is not connected or its wire is cut. (Normal operation after connecting a sensor)
LLL	When the measured input temperature is lower than input range of the sensor.
HHH	When the measured input temperature is higher than input range of the sensor.

- When error [**oPn**] / [**LLL**] / [**HHH**] occur
When it is returned to the connection / using range, it operates normally.
- The priority of 'Error' display : **oPn** → **HHH**, **LLL**

◎ Output setting for error[**oEr**]

For error, the statue of output is set by [**oEr**] of setting group 2.

- For setting OFF: Output is always OFF for error.
- For setting ON: Output is always ON for error.
- Factory default : OFF

◎ Lock setting[**Lc**]

- This function limits the change of parameters on each setting group.
It can be set setting group 2.
- For setting[**Lc1**], changing the parameter, "Setting group 2", is not available.
- For setting[**Lc2**], changing the parameter, "Setting group 1 + Setting group 2", is not available.
- For setting[**Lc3**], changing the parameter, "Setting group 1 + Setting group 2 + SV setting parameter", is not available.
- For setting [**oFF**], Lock off for all setting group

■ Proper usage

1. Installation environment
 - ① It shall be used indoor.
 - ② Altitude Max. 2000m.
 - ③ Pollution Degree 2.
 - ④ Installation Category II.
2. Please install power switch or circuit-breaker in order to supply or cut the power.
3. The switch or circuit-breaker should be installed near by users.
4. Do not use this product as Volt-meter or Ampere-meter.
5. Please separate with power/high-voltage line avoid from inductive noise.
6. In case of using RTD sensor, 3wire type must be used. and if it is required to extend the line, 3wires must be used with the same thickness as the line. It might cause the deviation of temperature.
7. In case of making power line and input signal line closely, line filter for noise protection should be installed at power line and input signal line should be shielded.
8. Do not use in a place with the high frequency machinery. (High frequency welding machine & sewing machine, large capacity SCR controller)